

STRUCTURE TYPE CODE	DESCRIPTION	DIM. 'A'	DIM. 'B'
21	21' SIGNAL ARM	6579	6249
26	26' SIGNAL ARM	8103	7773

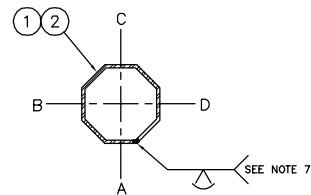

SECTION 1  
NTS

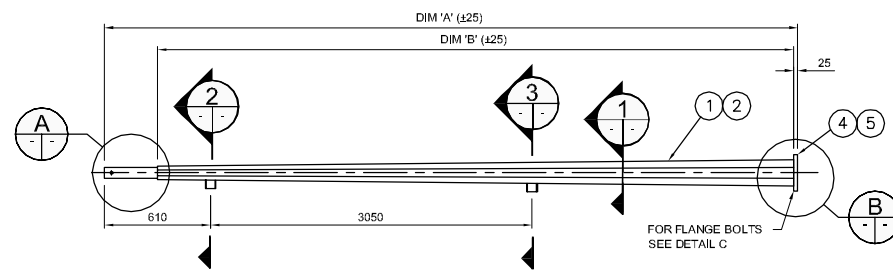

REACH ARM ELEVATION  
NTS

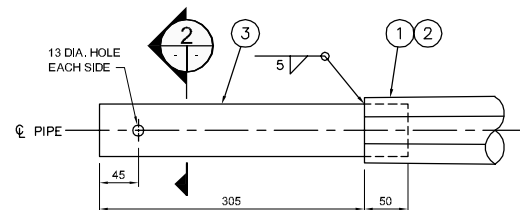

DETAIL A  
NTS

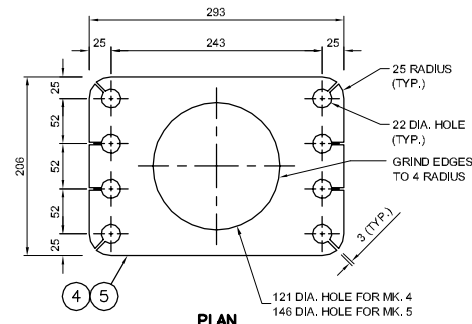

PLAN

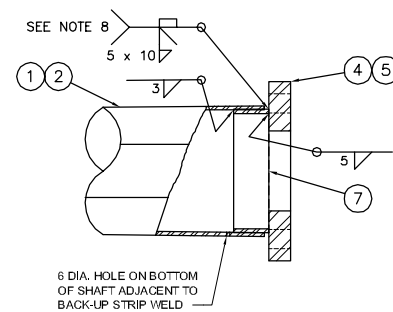

SECTION 2  
NTS

DETAIL B  
NTS

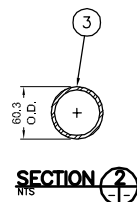

SECTION 3  
NTS

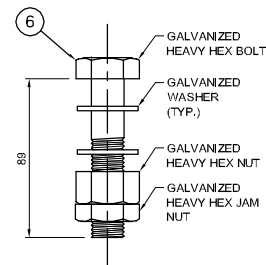

DETAIL C  
NTS

BILL OF MATERIALS						
MK. NO.	QTY. REQ'D.	DESCRIPTION	SIZE	MATERIAL	REMARKS	LINE NO.
<b>6.401 m (21') SIGNAL ARM - 21</b>						
1	1	OCTAGONAL SECTION SHAFT	153 A/F - 73 A/F x 4.554	CSA G40.21 350W		2
3	1	PIPE TENON	60.3 O.D. x 3.91 x 355	ASTM A53 GR. B SCH. 40		3
4	1	FLANGE PLATE	25 x 206 x 293	CSA G40.21 300W		4
6	8	FLANGE BOLTS	19 (3/4") DIA. x 89	ASTM A325	SEE DETAIL C	5
7	1	BACK-UP STRIP PLATE	4.554 x 40	CSA G40.21 350W		6
8	2	PIPE PENETRATION (1 1/2") C/W PLUG	48 O.D. X 25	ASTM A53 GR. B SCH. 40	REMOVE BURRS AND SHARP EDGES	7
<b>7.925 m (26') SIGNAL ARM - 26</b>						
2	1	OCTAGONAL SECTION SHAFT	178 A/F - 73 A/F x 4.554	CSA G40.21 350W		10
3	1	PIPE TENON	60.3 O.D. x 3.91 x 355	ASTM A53 GR. B SCH. 40		11
5	1	FLANGE PLATE	25 x 206 x 293	CSA G40.21 300W		12
6	8	FLANGE BOLTS	19 (3/4") DIA. x 89	ASTM A325	SEE DETAIL C	13
7	1	BACK-UP STRIP PLATE	4.554 x 40	CSA G40.21 350W		14
8	2	PIPE PENETRATION (1 1/2") C/W PLUG	48 O.D. X 25	ASTM A53 GR. B SCH. 40	REMOVE BURRS AND SHARP EDGES	15

APPROXIMATE TOTAL MASS: 21' ARM - 94 kg  
26' ARM - 126 kg

**NOTES:**

- ALL MATERIALS, EXCEPT STAINLESS STEEL ITEMS, SHALL BE HOT DIP GALVANIZED IN ACCORDANCE WITH ASTM A123-09 (PLUS LATEST REVISIONS) WITH NET RETENTION OF 610 g/m<sup>2</sup>.
- PROVIDE RAISED IDENTIFICATION NUMBER WITH WELDING ELECTRODE AS PER SPECIFICATION, STRUCTURE TYPE CODE INDICATED IN TABLE THIS DRAWING.
- SHIP WITH BOLTS C/W NUTS AND WASHERS IN FLANGE.
- PROVIDE RAISED "T" ON TOP OF ARM NEAR FLANGE PLATE USING WELDING ELECTRODE.
- GRIND ALL SHARP POINTS AND EDGES.
- TO BE USED WITH MEDIUM DUTY SHAFTS ONLY.
- LONGITUDINAL SEAM WELD SHALL HAVE 60% MINIMUM PENETRATION EXCEPT WITHIN 150 mm OF FLANGE PLATE SHALL BE COMPLETE PENETRATION.
- EXTERIOR WELD JOINING ARM SHAFT TO FLANGE PLATE SHALL BE AN UNEQUAL LEG COMPLETE PENETRATION WELD WITH THE LONG LEG OF THE WELD ALONG THE ARM, TERMINATING AT 30' FROM THE ARM'S SURFACE.

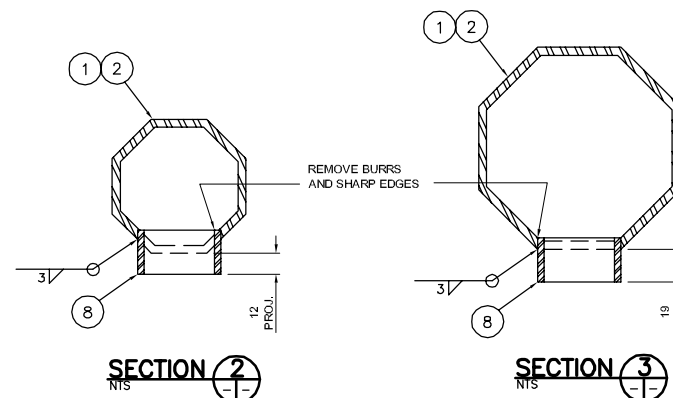

SECTION 2  
NTS

SECTION 3  
NTS

G:\CAD\125954\Contract\Current\REACH ARM.dwg



REDUCED DRAWING  
N.T.S.

NO.	REVISIONS	DATE	BY	DATE
3	REVISED BY DILLON CONSULTING	1/10/14	CDW	
2	REVISED BY DILLON CONSULTING	7/25/13	CDW	
1	ISSUED BY DILLON CONSULTING	1/14/13	CDW	

DESIGNED BY	CDW
DRAWN BY	JGW
CHECKED BY	SSR
APPROVED BY	-
HOR. SCALE	NTS
VERTICAL SCALE	NTS

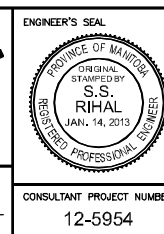
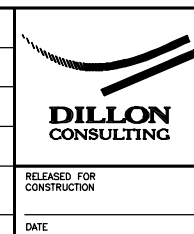

**THE CITY OF WINNIPEG PUBLIC WORKS DEPARTMENT**

21' & 26' TRAFFIC SIGNAL ARMS

CITY DRAWING NUMBER: N/A  
SHEET 9 OF 17  
CONSULTANT DRAWING NUMBER: N/A